

DS34LV86T

3V Enhanced CMOS Quad Differential Line Receiver

General Description

The DS34LV86T is a high speed quad differential CMOS receiver that meets the requirements of both TIA/EIA-422-B and ITU-T V.11. The CMOS DS34LV86T features typical low static I_{CC} of 9 mA which makes it ideal for battery powered and power conscious applications. The TRI-STATE® enables, EN, allow the device to be disabled when not in use to minimize power consumption. The dual enable scheme allows for flexibility in turning receivers on and off.

The receiver output (RO) is guaranteed to be High when the inputs are left open. The receiver can detect signals as low as ± 200 mV over the common mode range of ± 10 V. The receiver outputs (RO) are compatible with TTL and LVCMOS levels.

Features

- Low power CMOS design (30 mW typical)
- Interoperable with existing 5V RS-422 networks
- Industrial temperature range
- Meets TIA/EIA-422-B (RS-422) and ITU-T V.11 recommendation
- 3.3V Operation
- ± 7 V common mode range @ $V_{ID} = 3$ V
- ± 10 V common mode range @ $V_{ID} = 0.2$ V
- Receiver OPEN input failsafe feature
- Guaranteed AC parameter:
Maximum Receiver Skew: 4 ns
Transition time: 10 ns
- Pin compatible with DS34C86T
- 32 MHz Toggle Frequency
- >6.5k ESD Tolerance (HBM)
- Available in SOIC packaging

Connection Diagram

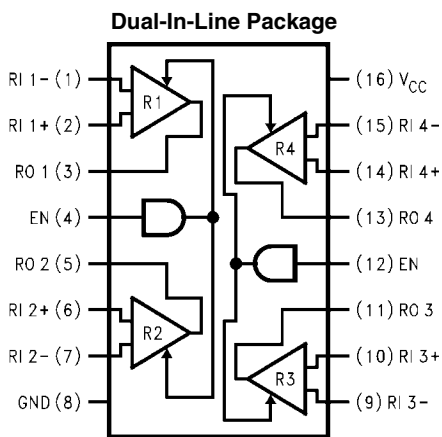

Top View
Order Number DS34LV86TM
See NS Package Number M16A

1264401

Truth Table

Enable EN	Inputs RI+–RI–	Output RO
L	X	Z
H	$V_{ID} \geq +0.2$ V	H
H	$V_{ID} \leq -0.2$ V	L
H	Open†	H

L = Logic Low
H = Logic High
X = Irrelevant
Z = TRI-STATE
† = Open, Not Terminated

Absolute Maximum Ratings (Note 1)

If Military/Aerospace specified devices are required, please contact the National Semiconductor Sales Office/ Distributors for availability and specifications.

Supply Voltage (V_{CC})	+7V
Enable Input Voltage (EN)	+7V
Receiver Input Voltage (V_{ID} : RI+, RI-)	±14V
Receiver Input Voltage (V_{CM} : RI+, RI-)	±14V
Receiver Output Voltage (RO)	-0.5V to $V_{CC} + 0.5V$
Receiver Output Current (RO)	±25 mA
Maximum Package Power Dissipation @ +25°C	
M Package	1190 mW
Derate M Package	9.8 mW/°C above +25°C

Storage Temperature Range	-65°C to +150°C
Lead Temperature Range	
Soldering (4 Seconds)	+260°C
ESD Ratings (HBM, 1.5k, 100 pF)	
Receiver Inputs and Enables	≥6.5 kV
Other Pins	≥2 kV

Recommended Operating Conditions

	Min	Typ	Max	Units
Supply Voltage (V_{CC})	3.0	3.3	3.6	V
Operating Free Air Temperature (T_A)	-40	+25	+85	°C

Electrical Characteristics (Notes 2, 3)

Over Supply Voltage and Operating Temperature ranges, unless otherwise specified.

Symbol	Parameter	Conditions	Pin	Min	Typ	Max	Units	
V_{TH}	Differential Input Threshold	$V_{OUT} = V_{OH}$ or V_{OL} $-7V < V_{CM} < +7V$	RI+, RI-	-200	±17.5	+200	mV	
V_{HY}	Hysteresis	$V_{CM} = 1.5V$			35		mV	
V_{IH}	Minimum High Level Input Voltage		EN	2.0			V	
V_{IL}	Minimum Low Level Input Voltage					0.8	V	
R_{IN}	Input Resistance	$V_{IN} = -7V, +7V$ (Other Input = GND)		5.0	8.5		kΩ	
I_{IN}	Input Current (Other Input = 0V, Power On or $V_{CC} = 0V$)	$V_{IN} = +10V$	RI+, RI-	0	1.1	1.8	mA	
		$V_{IN} = +3V$		0	0.27		mA	
		$V_{IN} = 0.5V$			-0.02		mA	
		$V_{IN} = -3V$		0	-0.43		mA	
		$V_{IN} = -10V$		0	-1.26	-2.2	mA	
I_{EN}		$V_{IN} = 0V$ to V_{CC}	EN			±1	μA	
V_{OH}	High Level Output Voltage	$I_{OH} = -6 mA, V_{ID} = +1V$ $I_{OH} = -6 mA, V_{ID} = OPEN$	RO	2.4	3		V	
V_{OH}	High Level Output Voltage	$I_{OH} = -100 μA, V_{ID} = +1V$ $I_{OH} = -100 μA, V_{ID} = OPEN$			$V_{CC} - 0.1$		V	
V_{OL}	Low Level Output Voltage	$I_{OL} = +6 mA, V_{ID} = -1V$				0.13	0.5	V
I_{OZ}	Output TRI-STATE Leakage Current	$V_{IN} = V_{CC}$ or GND EN = V_{IL}					±50	μA
I_{SC}	Output Short Circuit Current	$V_O = 0V, V_{ID} ≥ 200 mV $ (Note 4)			-10	-35	-70	mA
I_{CC}	Power Supply Current	No Load, All RI+, RI- = Open, EN = V_{CC} or GND		V_{CC}		9	15	mA

Switching Characteristics (Notes 3, 9, 10)

Over Supply Voltage and Operating Temperature ranges, unless otherwise specified.

Symbol	Parameter	Conditions	Min	Typ	Max	Units
t_{PHL}	Propagation Delay High to Low	$C_L = 15 \text{ pF}$ (Figures 1, 2)	6	17.5	35	ns
t_{PLH}	Propagation Delay Low to High		6	17.8	35	ns
t_r	Rise Time (20% to 80%)		4.1	10	ns	
t_f	Fall Time (80% to 20%)		3.3	10	ns	
t_{PHZ}	Disable Time	$C_L = 50 \text{ pF}$ (Figures 3, 4)			40	ns
t_{PLZ}	Disable Time				40	ns
t_{PZH}	Enable Time				40	ns
t_{PZL}	Enable Time				40	ns
t_{SK1}	Skew, $ t_{PHL} - t_{PLH} $ (Note 5)	$C_L = 15 \text{ pF}$		0.3	4	ns
t_{SK2}	Skew, Pin to Pin (Note 6)			0.6	4	ns
t_{SK3}	Skew, Part to Part (Note 7)			7	17	ns
f_{MAX}	Maximum Operating Frequency (Note 8)	$C_L = 15 \text{ pF}$	32			MHz

Note 1: "Absolute Maximum Ratings" are those values beyond which the safety of the device cannot be guaranteed. They are not meant to imply that the devices should be operated at these limits. The table of "Electrical Characteristics" specifies conditions of device operation.

Note 2: Current into device pins is defined as positive. Current out of device pins is defined as negative. All voltages are referenced to ground except V_{ID} .

Note 3: All typicals are given for: $V_{CC} = +3.3V$, $T_A = +25^\circ C$.

Note 4: Short one output at a time to ground. Do not exceed package power dissipation ratings.

Note 5: t_{SK1} is the $|t_{PHL} - t_{PLH}|$ of a channel.

Note 6: t_{SK2} is the maximum skew between any two channels within a device, on either edge.

Note 7: t_{SK3} is the difference in propagation delay times between any channels of any devices. This specification (maximum limit) applies to devices within $V_{CC} \pm 0.1V$ of one another, and a $\Delta T_A = \pm 5^\circ C$ (between devices) within the operating temperature range. This parameter is guaranteed by design and characterization.

Note 8: All channels switching, output duty cycle criteria is 40%/60% measured at 50% Input = 1V to 2V, 50% Duty Cycle, $t_r/t_f \leq 5$ ns. This parameter is guaranteed by design and characterization.

Parameter Measurement Information

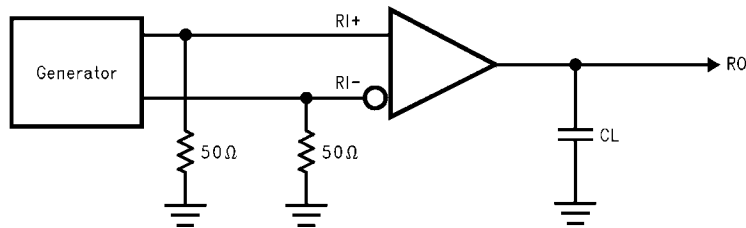

1264402

FIGURE 1. Receiver Propagation Delay and Transition Time Test Circuit (Notes 9, 10)

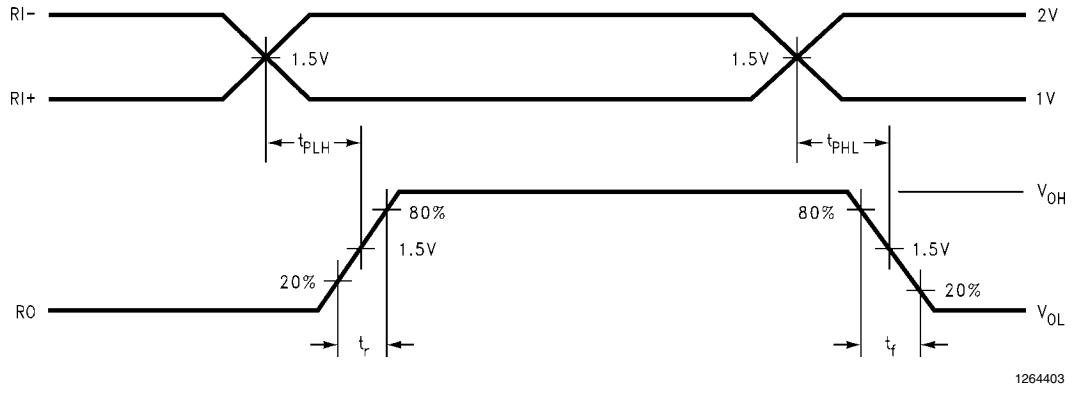

FIGURE 2. Receiver Propagation Delay and Transition Time Waveform (Notes 9, 10)

Note 9: Generator waveform for all tests unless otherwise specified: $f = 1 \text{ MHz}$, Duty Cycle = 50%, $Z_0 = 50\Omega$, $t_r \leq 10 \text{ ns}$, $t_f \leq 10 \text{ ns}$.

Note 10: C_L includes probe and jig capacitance.

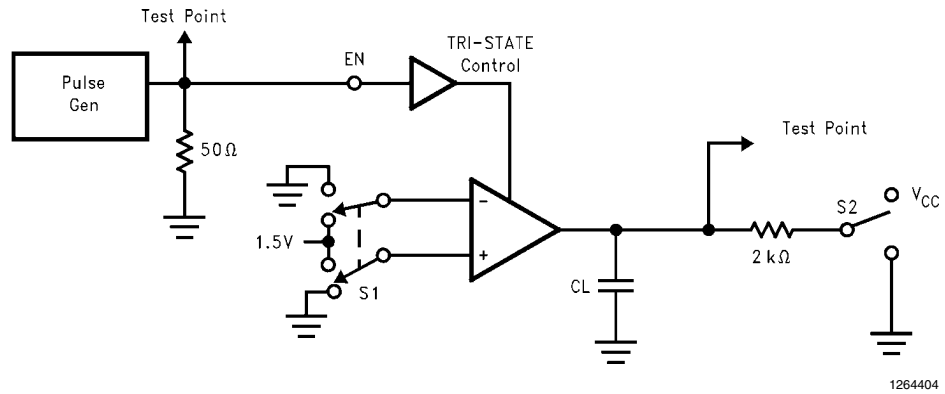

FIGURE 3. Receiver TRI-STATE Test Circuit

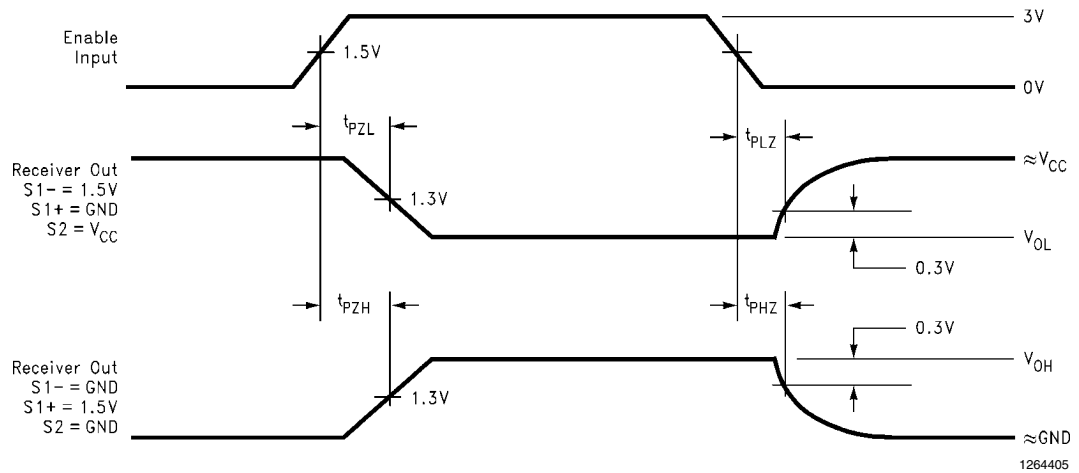

FIGURE 4. Receiver TRI-STATE Output Enable and Disable Waveforms (Notes 9, 10)

Typical Application Information

General application guidelines and hints for differential drivers receivers may be found in the following application notes:

AN-214, AN-457, AN-805, AN-847, AN-903, AN-912, AN-916

Power Decoupling Recommendations: Bypass caps must be used on power pins. High frequency ceramic (surface mount

is recommended) 0.1 μF in parallel with 0.01 μF at the power supply pin. A 10 μF or greater solid tantalum or electrolytic should be connected at the power entry point on the printed circuit board.

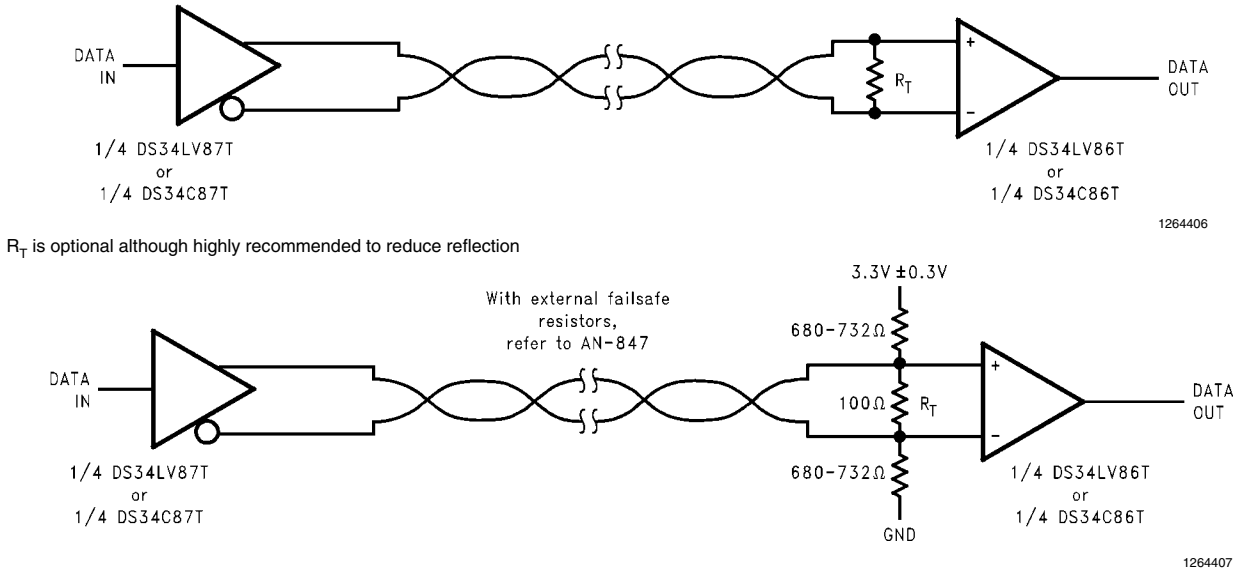

FIGURE 5. Typical Receiver Connections

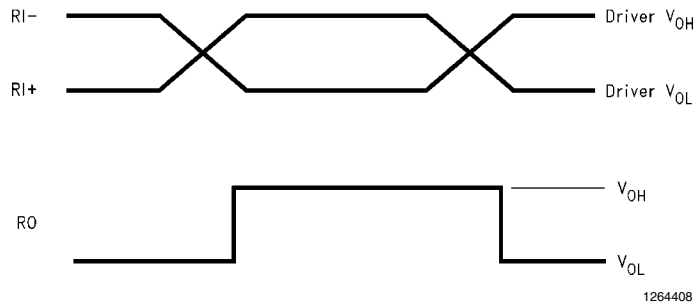
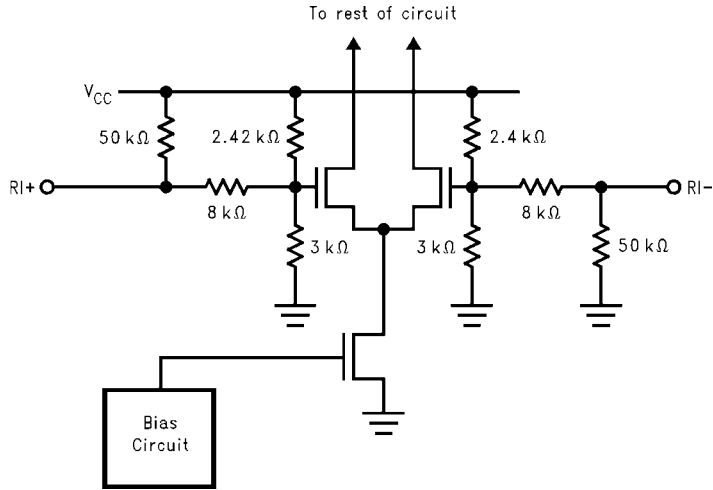
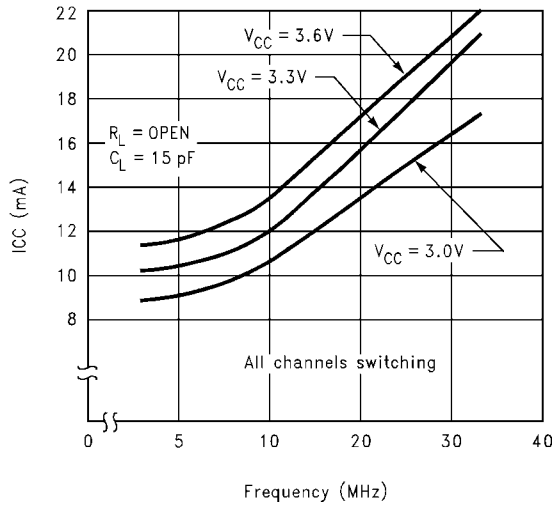

FIGURE 6. Typical Receiver Output Waveforms



1264409

FIGURE 7. Typical Receiver Input Circuit



1264410

FIGURE 8. Typical I_{CC} vs Frequency

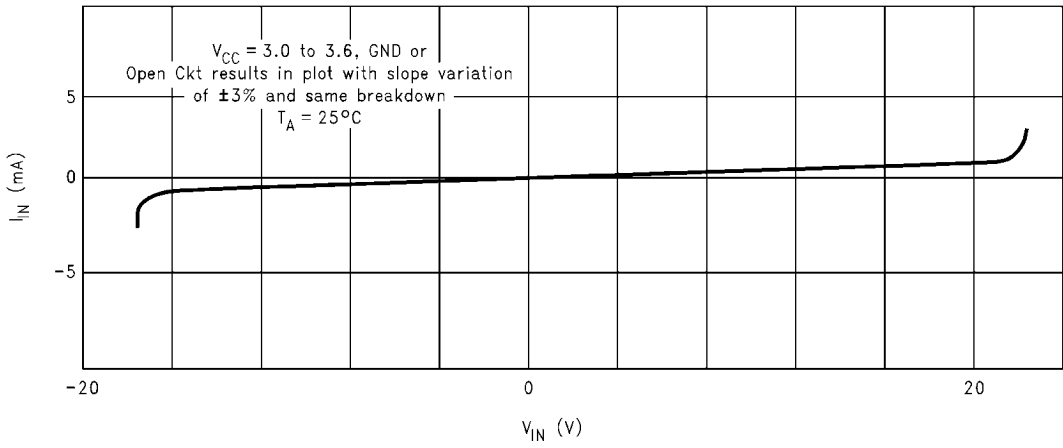

1264411

FIGURE 9. I_{IN} vs V_{IN} (Power On, Power Off)

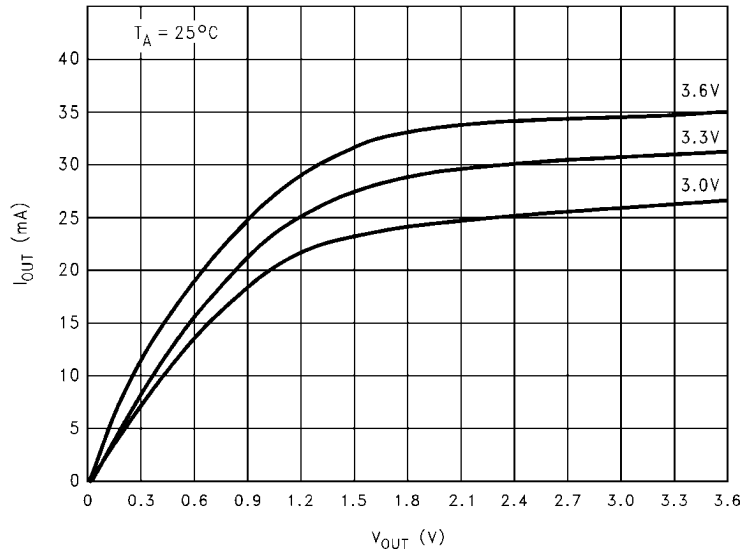

1264412

FIGURE 10. I_{OL} vs V_{OL}

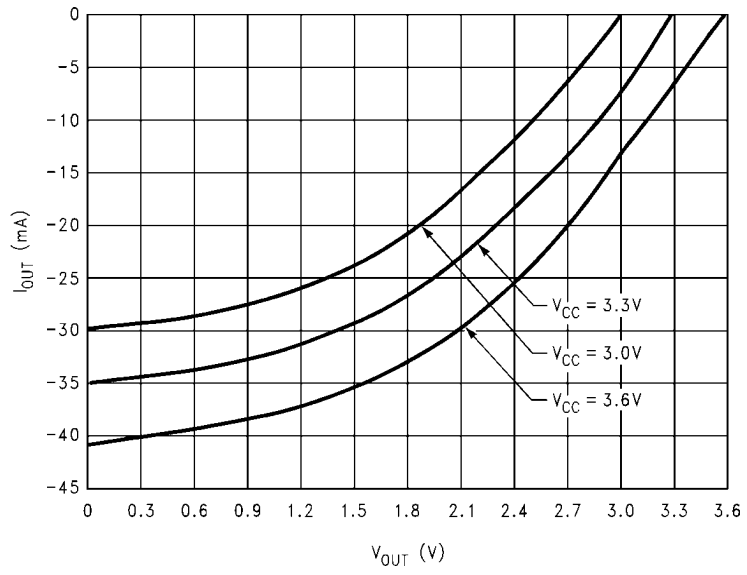

1264413

FIGURE 11. I_{OH} vs V_{OH}

Notes

For more National Semiconductor product information and proven design tools, visit the following Web sites at:

Products		Design Support	
Amplifiers	www.national.com/amplifiers	WEBENCH	www.national.com/webench
Audio	www.national.com/audio	Analog University	www.national.com/AU
Clock Conditioners	www.national.com/timing	App Notes	www.national.com/appnotes
Data Converters	www.national.com/adc	Distributors	www.national.com/contacts
Displays	www.national.com/displays	Green Compliance	www.national.com/quality/green
Ethernet	www.national.com/ethernet	Packaging	www.national.com/packaging
Interface	www.national.com/interface	Quality and Reliability	www.national.com/quality
LVDS	www.national.com/lvds	Reference Designs	www.national.com/refdesigns
Power Management	www.national.com/power	Feedback	www.national.com/feedback
Switching Regulators	www.national.com/switchers		
LDOs	www.national.com/lido		
LED Lighting	www.national.com/led		
PowerWise	www.national.com/powerwise		
Serial Digital Interface (SDI)	www.national.com/sdi		
Temperature Sensors	www.national.com/tempsensors		
Wireless (PLL/VCO)	www.national.com/wireless		

THE CONTENTS OF THIS DOCUMENT ARE PROVIDED IN CONNECTION WITH NATIONAL SEMICONDUCTOR CORPORATION ("NATIONAL") PRODUCTS. NATIONAL MAKES NO REPRESENTATIONS OR WARRANTIES WITH RESPECT TO THE ACCURACY OR COMPLETENESS OF THE CONTENTS OF THIS PUBLICATION AND RESERVES THE RIGHT TO MAKE CHANGES TO SPECIFICATIONS AND PRODUCT DESCRIPTIONS AT ANY TIME WITHOUT NOTICE. NO LICENSE, WHETHER EXPRESS, IMPLIED, ARISING BY ESTOPPEL OR OTHERWISE, TO ANY INTELLECTUAL PROPERTY RIGHTS IS GRANTED BY THIS DOCUMENT.

TESTING AND OTHER QUALITY CONTROLS ARE USED TO THE EXTENT NATIONAL DEEMS NECESSARY TO SUPPORT NATIONAL'S PRODUCT WARRANTY. EXCEPT WHERE MANDATED BY GOVERNMENT REQUIREMENTS, TESTING OF ALL PARAMETERS OF EACH PRODUCT IS NOT NECESSARILY PERFORMED. NATIONAL ASSUMES NO LIABILITY FOR APPLICATIONS ASSISTANCE OR BUYER PRODUCT DESIGN. BUYERS ARE RESPONSIBLE FOR THEIR PRODUCTS AND APPLICATIONS USING NATIONAL COMPONENTS. PRIOR TO USING OR DISTRIBUTING ANY PRODUCTS THAT INCLUDE NATIONAL COMPONENTS, BUYERS SHOULD PROVIDE ADEQUATE DESIGN, TESTING AND OPERATING SAFEGUARDS.

EXCEPT AS PROVIDED IN NATIONAL'S TERMS AND CONDITIONS OF SALE FOR SUCH PRODUCTS, NATIONAL ASSUMES NO LIABILITY WHATSOEVER, AND NATIONAL DISCLAIMS ANY EXPRESS OR IMPLIED WARRANTY RELATING TO THE SALE AND/OR USE OF NATIONAL PRODUCTS INCLUDING LIABILITY OR WARRANTIES RELATING TO FITNESS FOR A PARTICULAR PURPOSE, MERCHANTABILITY, OR INFRINGEMENT OF ANY PATENT, COPYRIGHT OR OTHER INTELLECTUAL PROPERTY RIGHT.

LIFE SUPPORT POLICY

NATIONAL'S PRODUCTS ARE NOT AUTHORIZED FOR USE AS CRITICAL COMPONENTS IN LIFE SUPPORT DEVICES OR SYSTEMS WITHOUT THE EXPRESS PRIOR WRITTEN APPROVAL OF THE CHIEF EXECUTIVE OFFICER AND GENERAL COUNSEL OF NATIONAL SEMICONDUCTOR CORPORATION. As used herein:

Life support devices or systems are devices which (a) are intended for surgical implant into the body, or (b) support or sustain life and whose failure to perform when properly used in accordance with instructions for use provided in the labeling can be reasonably expected to result in a significant injury to the user. A critical component is any component in a life support device or system whose failure to perform can be reasonably expected to cause the failure of the life support device or system or to affect its safety or effectiveness.

National Semiconductor and the National Semiconductor logo are registered trademarks of National Semiconductor Corporation. All other brand or product names may be trademarks or registered trademarks of their respective holders.

Copyright© 2008 National Semiconductor Corporation

For the most current product information visit us at www.national.com



**National Semiconductor
Americas Technical
Support Center**
Email: support@nsc.com
Tel: 1-800-272-9959

**National Semiconductor Europe
Technical Support Center**
Email: europe.support@nsc.com
German Tel: +49 (0) 180 5010 771
English Tel: +44 (0) 870 850 4288

**National Semiconductor Asia
Pacific Technical Support Center**
Email: ap.support@nsc.com

**National Semiconductor Japan
Technical Support Center**
Email: jpn.feedback@nsc.com